

LOC	DIST	REVISIONS					
G	14	P	LTR	DESCRIPTION	DATE	OWN	APVD
		K1		REVISED PER ECO-11-004820	11MAR11	RK	HMR

METRIC
 DIMENSIONS LISTED IN mm [INCHES]

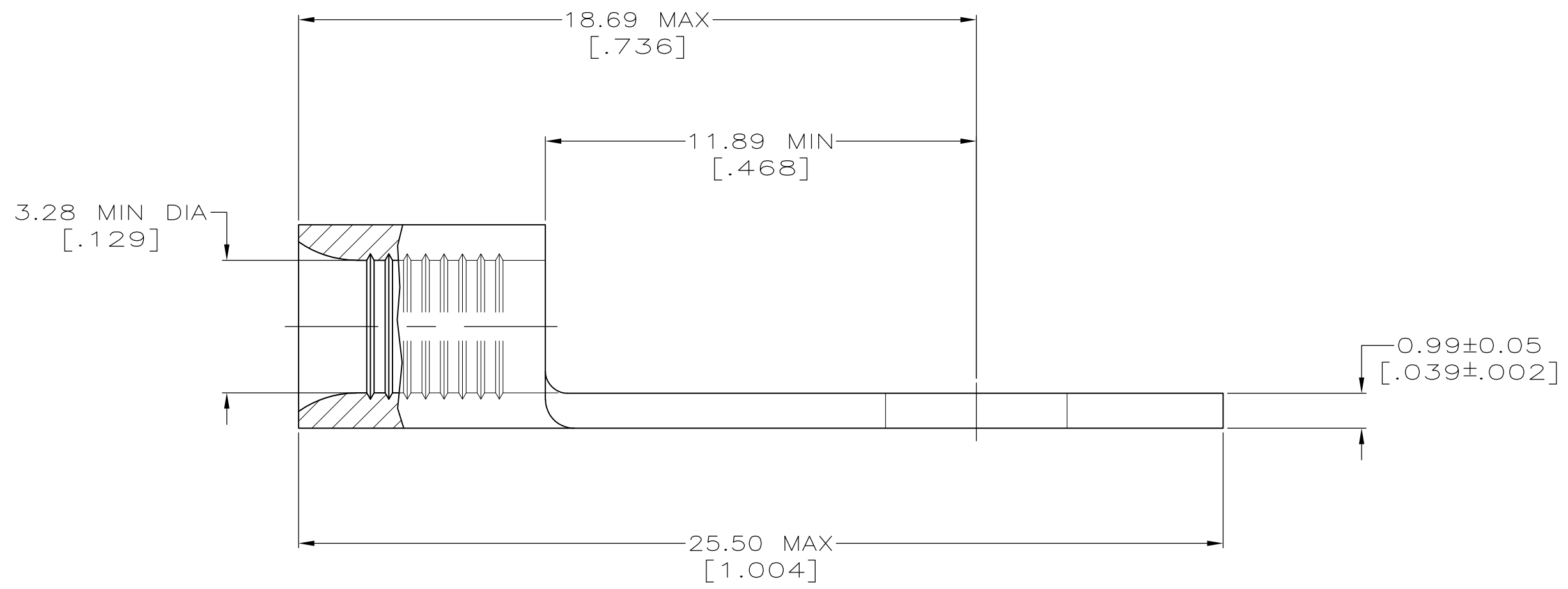
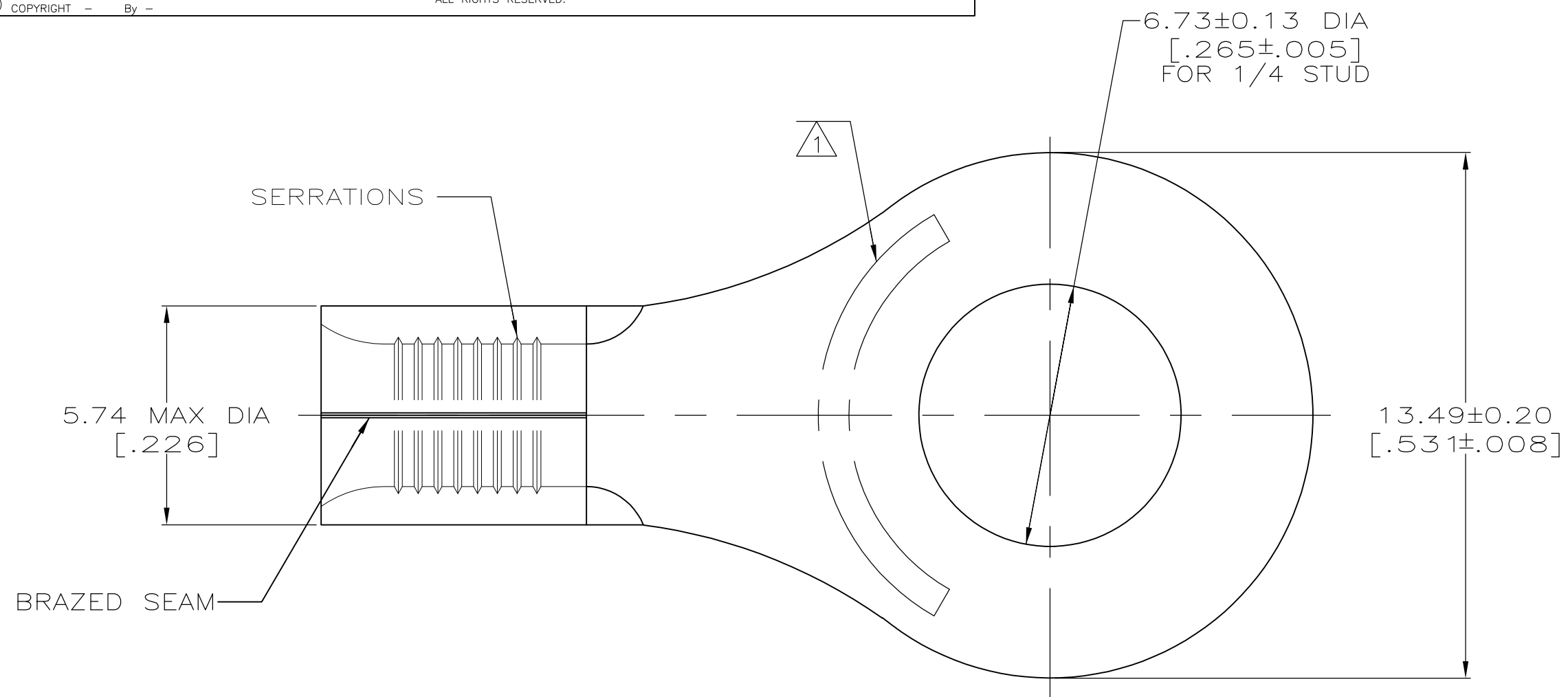

AMP WIRE RANGE	E13288 Listed
12-10 AWG SOLID OR STRANDED	12-10 AWG STRANDED
LR7189 Certified	MILITARY P/N AND CLASS
12-10 AWG SOLID OR STRANDED	NOT APPLICABLE

STAMP AMP 12-10* APPROX AS SHOWN

AMP INCORPORATED CUSTOMER SERVICE SYSTEMS		MAX RECOMMENDED OPERATING TEMPERATURE: 170° C MAX
FOR ADDITIONAL PRODUCT INFORMATION OR COPIES OF DRAWINGS AND TECHNICAL DOCUMENTS	PRODUCT INFORMATION CENTER 1-800-522-6752	VOLTAGE RATING: NOT APPLICABLE
FOR APPLICATION TOOLING INFORMATION	TOOLING ASSISTANCE CENTER 1-800-722-1111	WIRE CROSS SECTIONAL AREA RANGE: 2.62-6.64mm ² [5,180-13,100] CIR MILS SOLID OR STRANDED
FOR ORDER ENTRY	1-800-526-5142	THIS DRAWING IS A CONTROLLED DOCUMENT FOR AMP INCORPORATED. IT IS SUBJECT TO CHANGE AND THE CONTROLLING ENGINEERING ORGANIZATION SHOULD BE CONTACTED FOR THE LATEST REVISION.

50	LOOSE PIECE, BOX	8-33458-2
2500	ON TAPE	2-33458-3
----	LOOSE PIECE	33458
QUANTITY	PACKAGING TYPE	PART NO

THIS DRAWING IS A CONTROLLED DOCUMENT.		DWN TA BRINKMAN 3-17-93	TE Connectivity																	
DIMENSIONS: MM [INCHES]		CHK DA PATTERSON 3-17-93																		
TOLERANCES UNLESS OTHERWISE SPECIFIED:		APVD DE MILLER 3-17-93																		
<table border="1"> <tr><td>0 PLC</td><td>±</td><td>-</td></tr> <tr><td>1 PLC</td><td>±</td><td>-</td></tr> <tr><td>2 PLC</td><td>±</td><td>-</td></tr> <tr><td>3 PLC</td><td>±</td><td>-</td></tr> <tr><td>4 PLC</td><td>±</td><td>-</td></tr> <tr><td>ANGLES</td><td>±</td><td>± -</td></tr> </table>		0 PLC		±	-	1 PLC	±	-	2 PLC	±	-	3 PLC	±	-	4 PLC	±	-	ANGLES	±	± -
0 PLC	±	-																		
1 PLC	±	-																		
2 PLC	±	-																		
3 PLC	±	-																		
4 PLC	±	-																		
ANGLES	±	± -																		
MATERIAL COPPER PER ASTM B-152 ANNEALED	FINISH TIN PLATE 0.00254(0.00100)MIN THK PER MIL-1-10727	WEIGHT -	SIZE A2																	
CUSTOMER DRAWING		SCALE 8:1	DRAWING NO 00779																	
		SHEET 1 of 1	RESTRICTED TO -																	
		REV K1																		