

RECEIVER-615-2-SC-FRANKLIN

The 6x15x2.0 mm rectangular Franklin receiver is a high end miniature receiver specifically designed for mobile phones and smartphones where high quality voice transmission is required.

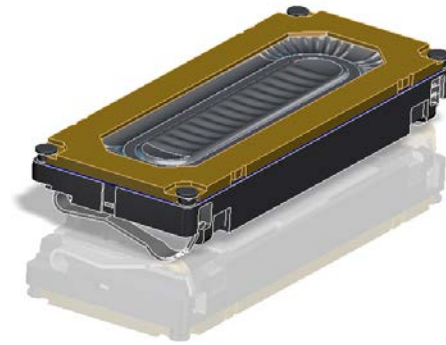

Features:

- High Sensitivity (71 dB/W/m)
- Additional dust protection meshes on rear
- 6kHz peak optimized for extended range without additional resonators
- Spring contacts for Pick&Place
- Compound membrane for minimum THD, Q-factor and tumbling
- 100% in-line measurement of specified acoustical and electrical parameters

Contents

1. Theory of operation.....3

2. Mechanical Layout and Dimensions.....4

 2.1. Main Dimensions.....4

 2.2. PWB Layout5

 2.3. Spring Force.....5

 2.4. Forces on component.....6

 2.5. Part Marking/Labeling.....7

 2.6. Material List.....8

3. Electrical and Acoustical Specifications.....9

 3.1. Frequency response and TND-Baffle.....9

 3.2. Frequency Response and THD-3.2HL Coupler.....10

 3.3. Electro-acoustic Parameters11

 3.4. Power handling.....12

 3.5. Measurement setup13

 3.6. Measured Parameters.....14

 3.7. Measurement adapter15

4. Environmental Conditions.....16

 4.1. Storage.....16

 4.2. Transportation.....16

 4.3. Functionality.....16

5. Environmental tests17

 5.1. Qualification tests.....17

 5.2. Reliability tests17

 5.3. Sample Size, Sequence17

 5.4. Period of Shelf-Life17

 5.5. Testing Procedures.....17

6. Related Documents21

7. Change History22

8. Disclaimer22

2403 260 00087

1. Theory of operation

RECEIVER-615-2-SC-FRANKLIN is a electro dynamic transducer, designed to translate electrical analog signals into sound. The input signal is fed into a coil in a magnetic field, which is attached to a membrane. Through the principle of the electromagnetic force, the membrane is moved according to the contents of the input signal.

2403 260 00087

2. Mechanical Layout and Dimensions

2.1. Main Dimensions

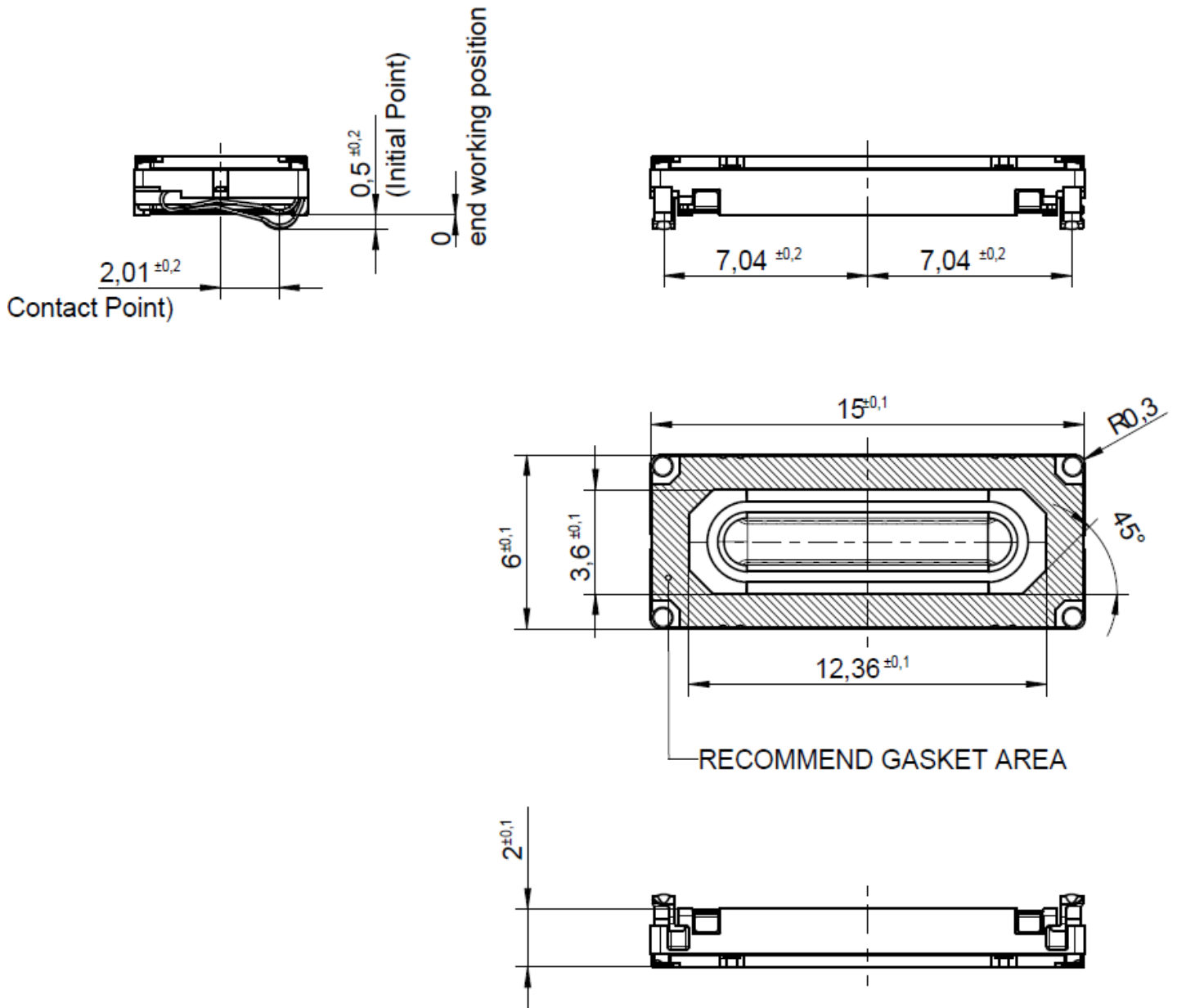

2403 260 00087

2.2. PWB Layout

PAD LAYOUT (VIEW TO PWB / TOPSIDE)

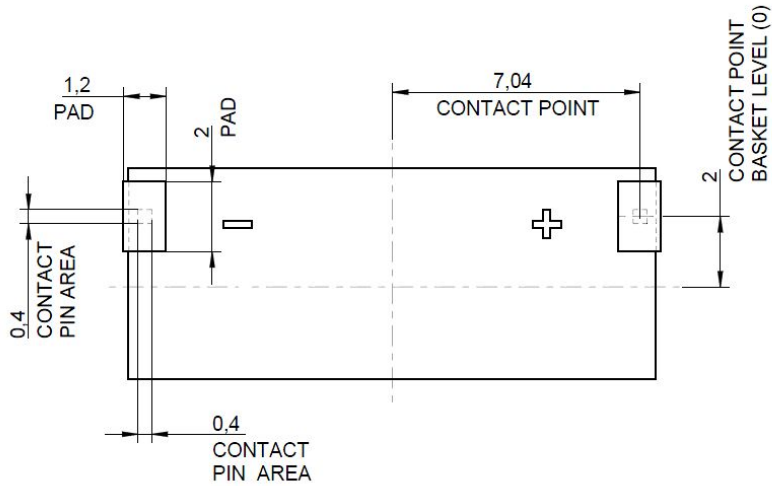

POSITIVE VOLTAGE ON PIN+

MOVES MEMBRANE IN DIRECTION OF ARROW

2.3. Spring Force

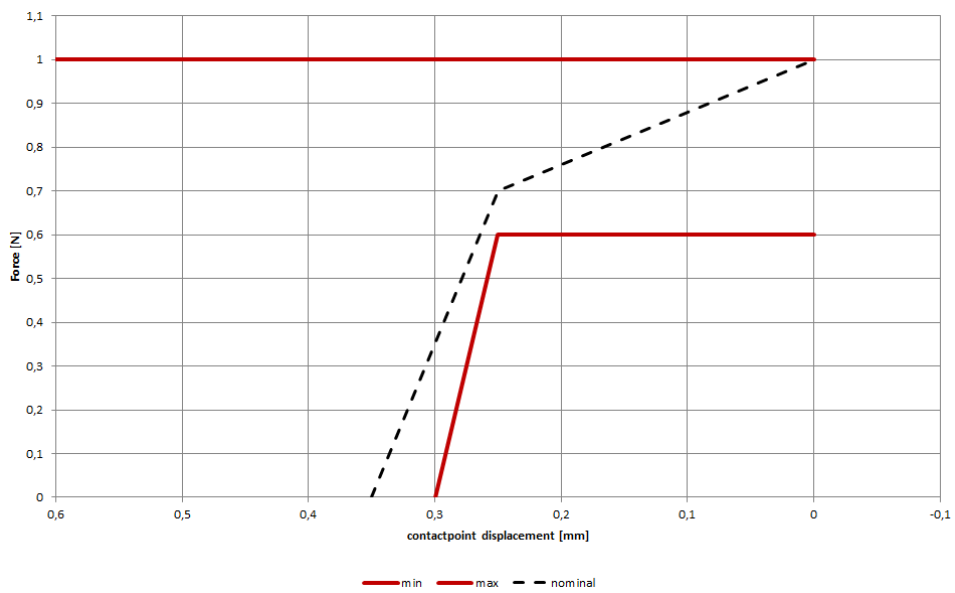

2403 260 00087

2.4. Forces on component

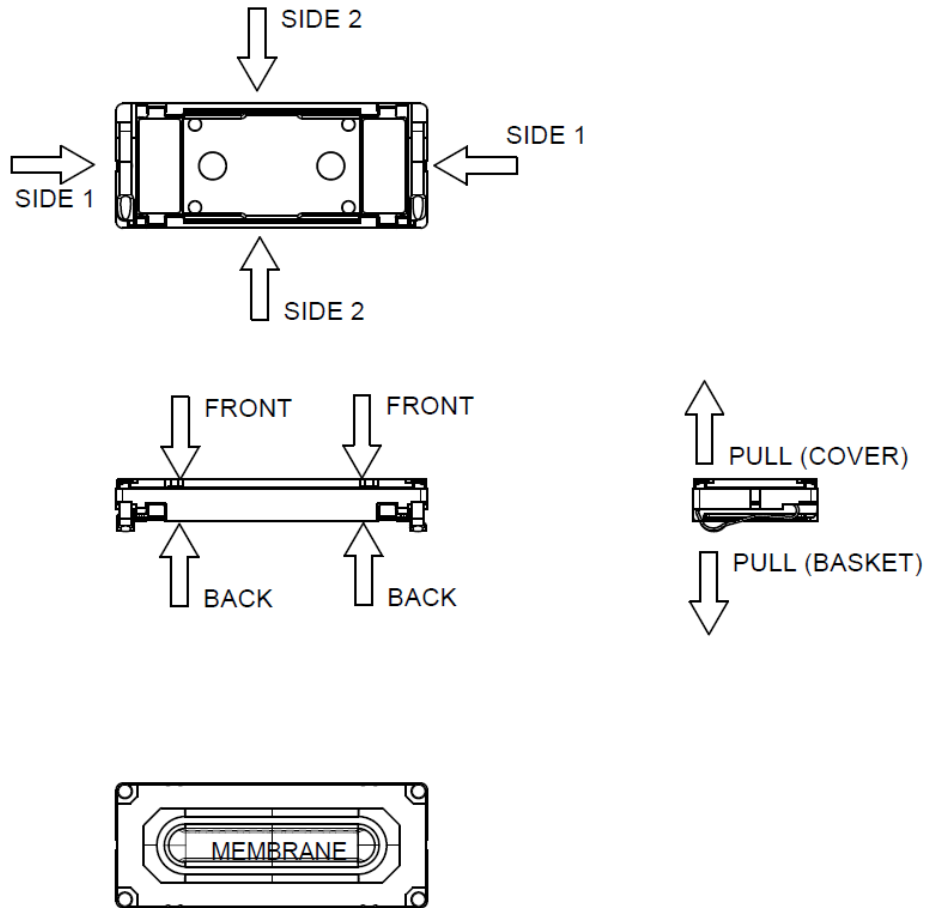

STATE	MINIMUM SURFACE OF PREASSURE [mm ²]	MAXIMUM PERMANENT FORCE [N]	MAXIMUM HANDLING FORCE [N]
FROM FRONT (DISTRIBUTED TO GASKET AREA) TO BACK (BASKET)	0	10	15
FROM SIDE 1 TO SIDE 1	3	10	15
FROM SIDE 2 TO SIDE 2	10	10	15
TO POT	0	0	0
TO MEMBRANE	0	0	0
PULL OF FORCE (COVER/BASKET)	0	0	5

2403 260 00087

2.6. Material List

- | | |
|--------------------------|-------------------------|
| 1. Material of basket: | Polycarbonate |
| 2. Material of membrane: | Polyarylate-Compound |
| 3. Material of pot: | soft magnetic Iron |
| 4. Material of magnet: | Nd Fe B |
| 5. Material of contact | CrNi-Steel, gold plated |
| 6. Material of cover: | Brass |
| 7. Rear Mesh: | Acrylic |
| 8. Dimensions: | 6x15x2 mm |
| 9. Mass: | 0,5 g |

2403 260 00087

3. Electrical and Acoustical Specifications

3.1. Frequency response and TND-Baffle

Typical frequency response measured on baffle according to chapter 3.5
(distance d = 1cm, p= 20mW, without back cavity)

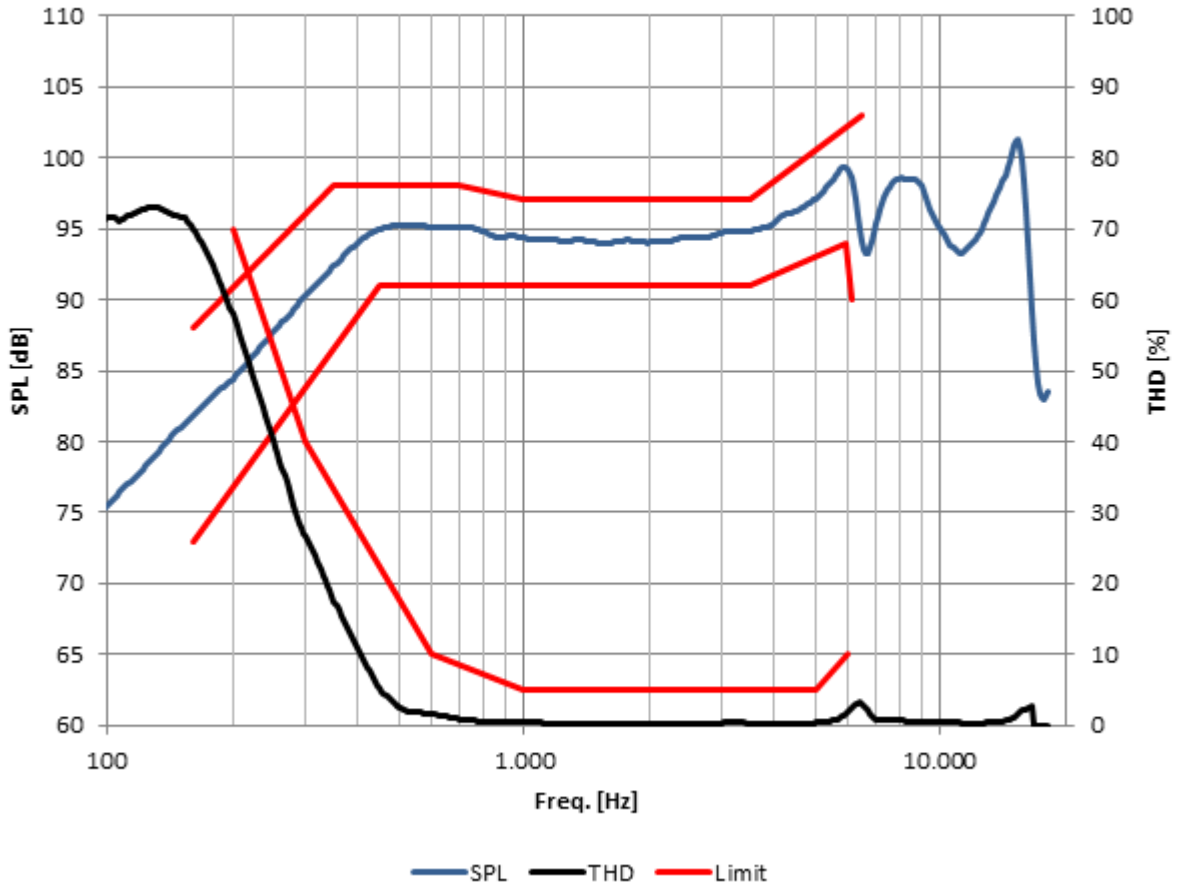

Tolerance window				
f [Hz]	lower limit [dB SPL]	upper limit [dB SPL]	f [Hz]	upper limit [%THD]
160	73	88	200	70
350	-	98	300	40
450	91	-	600	10
700	91	98	1000	5
1000	91	97	5000	5
3500	91	97	6000	10
5900	94	-		
6100	90	-		
6500	-	103		

2403 260 00087

3.2. Frequency Response and THD-3.2HL Coupler

Typical frequency response measured on 3.2HL Coupler
 (@DRP, p=20mW, without back cavity)

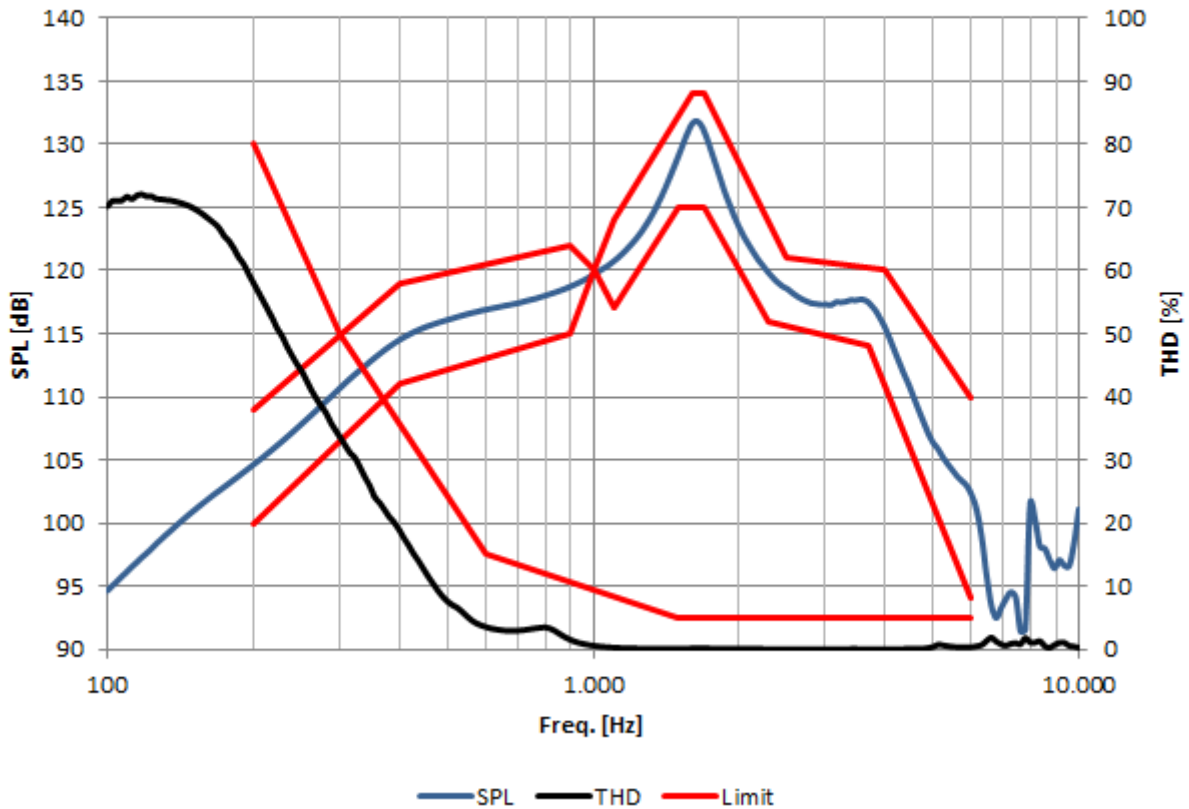

f [Hz]	lower limit [dB SPL] relative to 1kHz	upper limit [dB SPL] relative to 1kHz	f [Hz]	upper limit [%THD]
200	-20	-11	200	80
400	-9	-1	300	50
900	-5	2	600	15
1000	0	0	1500	5
1100	-3	4	6000	5
1500	5	-		
1600	-	14		
1700	5	14		
2300	-4	-		
2500	-	1		
3700	-6	-		
4000	-	0		
6000	-26	-10		



2403 260 00087

3.3. Electro-acoustic Parameters

Loudspeaker mounted in adapter acc. to 3.6.

1. Rated impedance	Z:	32Ω
2. Voice coil resistance	R:	28.8Ω±10%
3. Resonance frequency (measured @20mW)	f ₀ :	400Hz±12%
4. Maximum usable excursion x _{max}	p-p:	0.64mm p-p
5. Nominal characteristic sensitivity (calculated for 1W in 1m) average from 1kHz to 3kHz		71±2dB
5.1. Measured characteristic sensitivity (at 20mW in 1cm) average from 1kHz to 3kHz		94±2dB
6. THD	according chapter 3.1.	
7. Rub & buzz	< 60dB SPL (200Hz -2000Hz) in 1cm at 20mW (800mV _{eff})	

All acoustic measurements at 23±2°C

2403 260 00087

3.4. Power handling

Receiver mounted in lifetime test device (open rear/open front)
 (pink noise shaped according to diagram below, crest factor 2)

- | | | |
|------------------------------|--------------------------|------------|
| 1. Max short term power | (0,5sec. ON / 3sec. OFF) | 50mW (RMS) |
| Signal: lifetime test signal | | |
| 2. Max continuous power | (500h) | 20mW (RMS) |
| Signal: lifetime test signal | | |

Lifetime Test Signal: pink noise, 6dB crest factor, filtered with 2nd order high pass filter at 400Hz and with 2nd order low pass filter at 10kHz

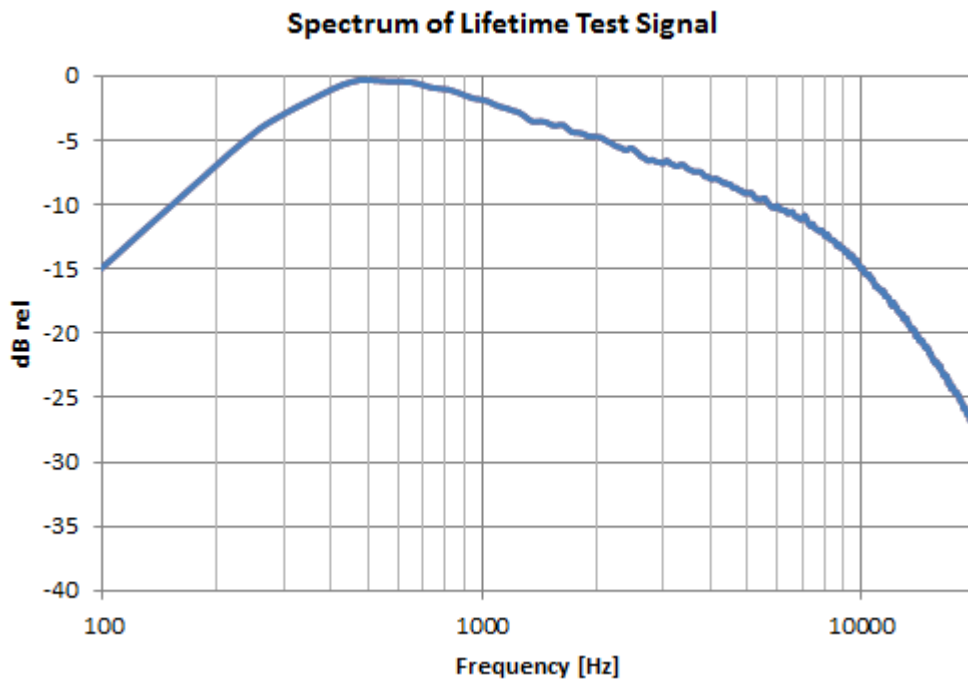

2403 260 00087

3.5. Measurement setup

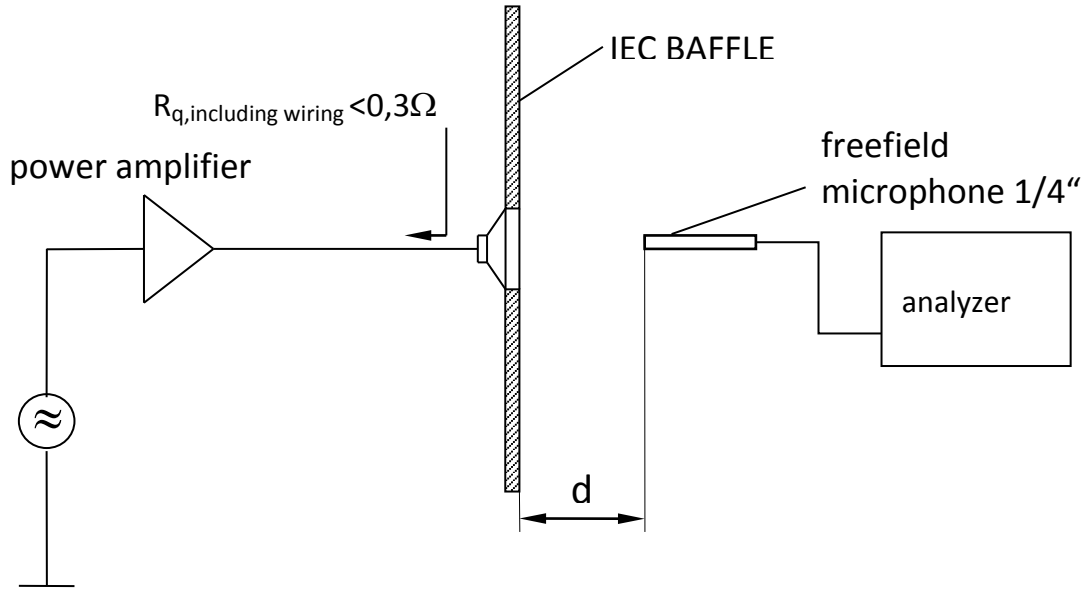

2403 260 00087

3.6. Measured Parameters

3.6.1. Sensitivity

SPL is expressed in dB rel 20 μ Pa, computed according to IEC 268-5. Measurement set up and parameters according chapter 3.4. This test is performed for 100% of products in the production line.

3.6.2. Frequency response

Frequency response is measured according test set up in chapter 3.4 data sheet and checked against the tolerance window defined in chapter 3.1. This Test is performed for 100% of products in the production line.

3.6.3. Total harmonic distortion (THD)

Is measured according IEC 268-5 (2nd to 5th harmonics) and test set up in chapter 3.4. This test is performed for 100% of products in the production line.

3.6.4. Rub& Buzz

Rub & Buzz will be measured in the Inline-measuring device with a sinusoidal sweep. Rub & Buzz is defined as the maximum level of no harmonic energy, expressed as signal to non-harmonic content ratio, in a certain frequency-range. Signal and evaluation criteria are according to chapter 3.2. This test is performed for 100% of products in the production line.

2403 260 00087

3.7. Measurement adapter

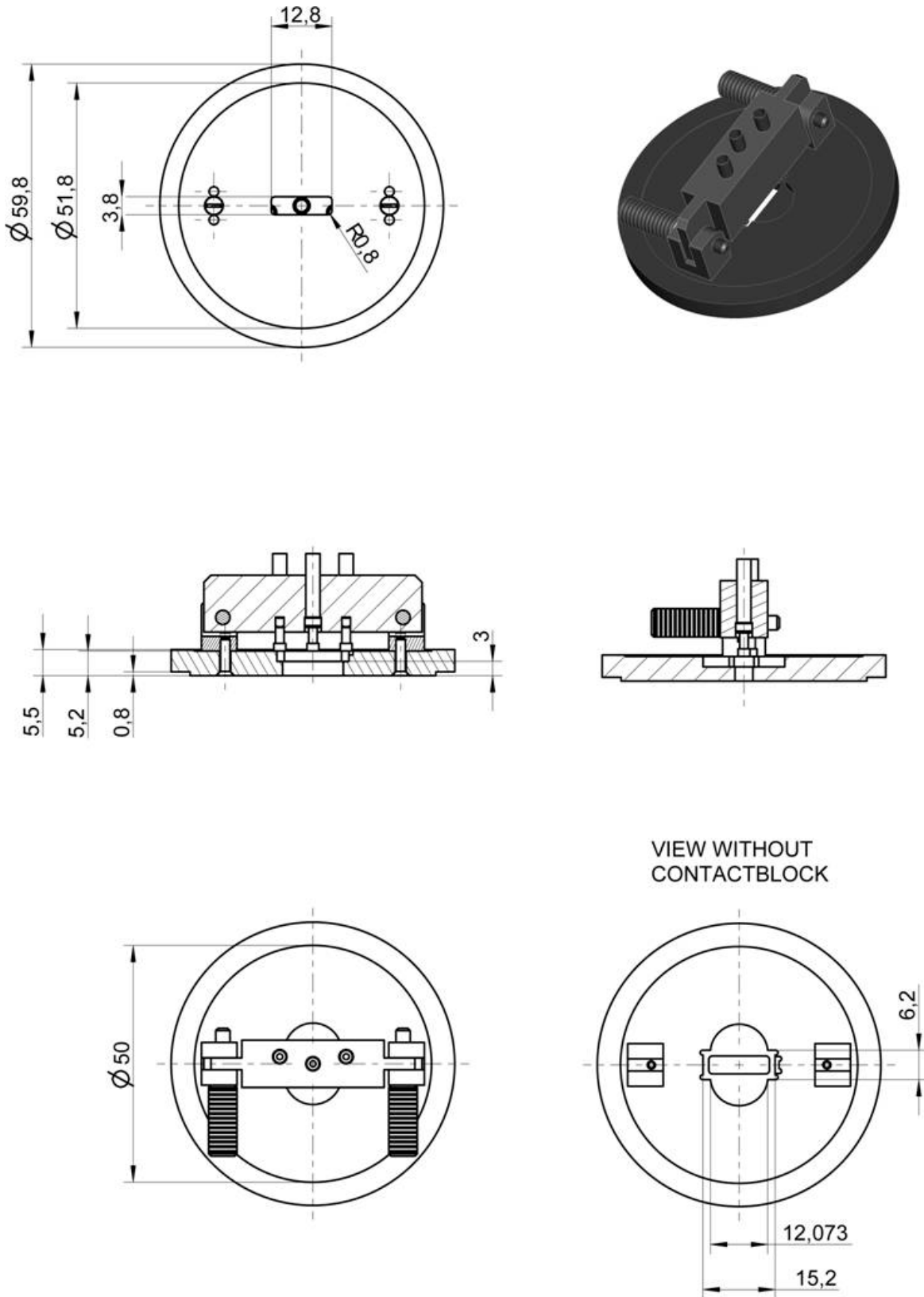

2403 260 00087

4. Environmental Conditions

4.1. Storage

The transducer fulfills the specified data after treatment according to the conditions of

ETS 300 019-2-1 Specification of environmental test: Storage
Test spec. T 1.2: Weather protected, not temperature controlled storage locations.

4.2. Transportation

The transducer fulfills the specified data after treatment according to the conditions of

ETS 300 019-2-2 Specification of environmental test: Transportation
Test Spec. T 2.3: Public Transportation

4.3. Functionality

The transducer fulfills the specified data after treatment according to the conditions of

ETS 300 019-2-5 Specification of environmental test: Ground vehicle installations
Test spec. T 5.1: Protected installation

ETS 300 019-2-7 Specification of environmental test: Portable and non-stationary use
Test spec. T 7.3E: Partly weather protected and non-weather protected locations.

5. Environmental tests

5.1. Qualification tests

According to our milestone plan (Product Creation Process), a complete qualification test will be done at design validation of products manufactured under serial conditions.

1x per year and product family a requalification takes place. The qualification process covers all tests described under 5.5 and a complete inspection.

5.2. Reliability tests

1x per month and product family samples are taken and submitted to tests described under 5.5.2

5.3. Sample Size, Sequence

Unless otherwise stated 20 arbitrary new samples will be used to perform each test for both, qualification and requalification test as described under 5.1 and 5.2.

5.4. Period of Shelf-Life

The period of shelf-life is 2 years.

5.5. Testing Procedures

5.5.1. Storage Tests

5.5.1.1. Cold Storage Test

Parameter	Test Method and Conditions	Duration	Evaluation Standard
Low Temperature Storage (Ref. EN 60068-2-1)	-40°C rel. humidity not controlled	168h	Measurements after 2 hours recovery time. All samples fully operable. All acoustical parameters according specification with tolerances increased by 50 %.

5.5.1.2. Heat Storage Test

Parameter	Test Method and Conditions	Duration	Evaluation Standard
Dry Heat Storage (Ref. EN 60068-2-2)	+85°C rel. humidity not controlled	168h	Measurements after 2 hours recovery time. All samples fully operable. All acoustical parameters according specification with tolerances increased by 50 %.

5.5.1.3. Temperature Cycle Test

Parameter	Test Method and Conditions	Duration	Evaluation Standard
Change of Temperature (Ref. EN 60068-2-14)	-40°C/+85°C Transition time <3 min. See Figure 5-1 below	5 cycles >2h for each temperature	Measurements after 2 hours recovery time. All samples fully operable. All acoustical parameters according specification with tolerances increased by 50 %.

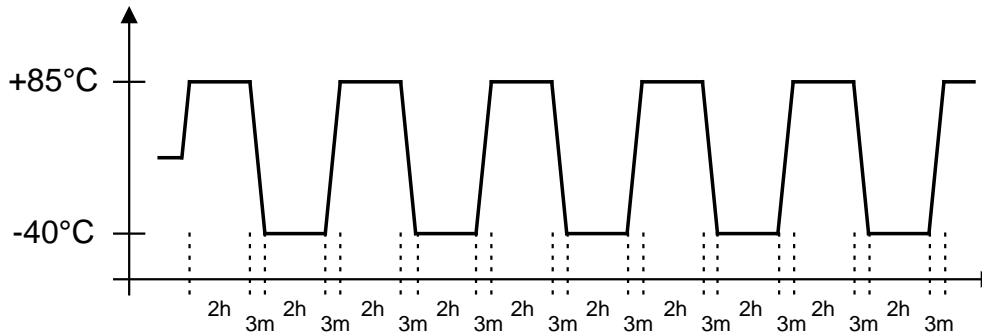

Figure 5-1: Temperature Cycle Test

5.5.1.4. Temperature / Humidity Cycle Test

Parameter	Test Method and Conditions	Duration	Evaluation Standard
Damp heat, cyclic (Ref. IEC 60068-2-30)	+25°C/+55°C 90% to 95% RH. Temp. change time <3h See Figure 5-2 below <u>Caution:</u> no condensed water on products!	6 cycles / 144h 12h at each temperature (inclusive temp ramp up/down)	Measurements after 2 hours recovery time. All samples fully operable. All acoustical parameters according specification with tolerances increased by 50 %.

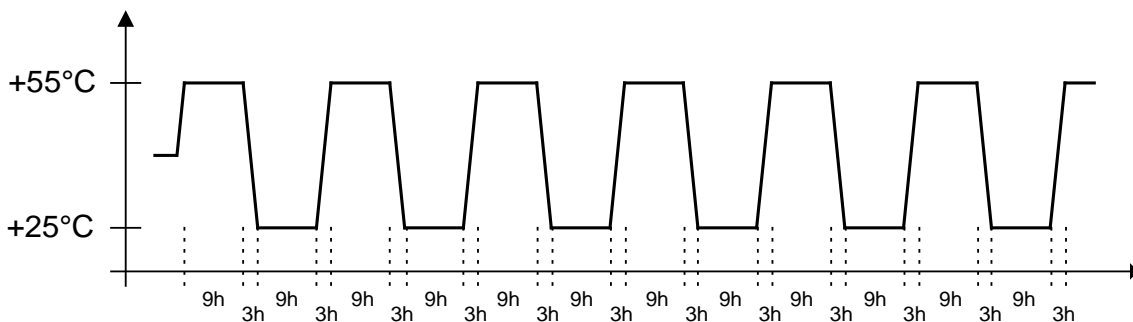

Figure 5-2: Temperature / Relative Humidity Cycle Test

5.5.2. Operating Tests

5.5.2.1. Cold Operation Test

Parameter	Test Method and Conditions	Duration	Evaluation Standard
Cold Operation Test (Ref. EN 60068-2-1)	-20°C rel. humidity not controlled signal acc. Chapter 3.3	72h	Measurements after 2 hours recovery time. All samples fully operable. THD may be increased after test. All other acoustical parameters according specification with tolerances increased by 50 %.

5.5.2.2. Dry Heat Operation Test

Parameter	Test Method and Conditions	Duration	Evaluation Standard
Dry Heat Operation (Ref. EN 60068-2-2)	+70°C rel. humidity not controlled signal acc. Chapter 3.3	500h	Measurements after 2 hours recovery time. All samples fully operable. The allowable change in sensitivity shall not be greater than 3 dB. All other acoustical parameters according specification with tolerances increased by 50 %.

5.5.3. Salt Mist Test

Parameter	Test Method and Conditions	Duration	Evaluation Standard
Salt Mist (Ref. IEC60068-2-52, Kb / Severity 2)	The part must be subjected to 2 hours spray of 5% NaCl salt mist, at 35°C then be left at 40°C and 95% RH for 22h.	3 cycles	The samples shall be washed after the test with distilled water and dried at T < 50°C. Component may have reduced performance, but must still function properly. The allowable sensitivity difference shall not be greater than ±3dB from initial sensitivity.

2403 260 00087

5.5.4. Guided Free Fall Test - protected product

Parameter	Test Method and Conditions	Conditions / Sample size	Evaluation Standard
Mechanical shock (Ref. IEC60068-2-32 Ed), Procedure 1	Speaker in drop test box or representative mechanics from a height of 1.5m onto concrete floor.	30 units Two drops on each side (2x6) One drop on each edge (1x12) Two drops on each corner (2x8) (40 drops in total)	Component may have reduced performance, but must still function properly. The allowable sensitivity difference shall not be greater than ± 3 dB from initial sensitivity.

5.5.5. Random Free Fall Test (Tumble Test) – protected product

Parameter	Test Method and Conditions	Conditions / Sample size	Evaluation Standard
Impact durability (in a Tumble Tester) (Ref. IEC60068-2-32 Ed) (SPR a7.1.1)	Speaker in drop test box or representative mechanics. Random drops on steel base.	30 units 180 drops, 1m DUT power off	Component may have reduced performance, but must still function properly. The allowable sensitivity difference shall not be greater than ± 3 dB from initial sensitivity.

5.5.6. Resistance to Electrostatic Discharge

Parameter	Test Method and Conditions	Conditions / Sample size	Evaluation Standard
Resistance to ESD IEC61000-4-2 Level 4 (SPR c 2.5.1)	One pole is grounded and the ESD pulse is applied to the other pole. The speaker must be stressed first with one polarisation and then with the other polarisation. DUT must be discharged between each ESD exposure. Level 4: contact +/- 8kV, air +/- 15kV	10 exposures on each polarity / 5 units DUT Power off	All samples fully operable. All acoustical parameters according specification with tolerances increased by 50%.

2403 260 00087

6. Related Documents

IEC 268-5	Sound System equipment Part 5: Loudspeaker
IEC 68-2	Environmental testing
EN 60068-2	Environmental testing
ISO 2859 - 1	Sampling procedures for inspection by attributes Part 1: Sampling plans indexed by acceptable quality level (AQL) for lot-by-lot inspection
ISO 3951	Sampling procedures and charts for inspection by variables for percent defectives.
ETS 300 019-2-1	Specification of environmental test: Storage Test spec. T 1.2: Weather protected, not temperature controlled storage locations
ETS 300 019-2-2	Specification of environmental test: Transportation Test spec. T 2.3: Public Transportation
ETS 300 019-2-5	Specification of environmental test: Ground vehicle installations Test spec. T 5.1: Protected installation
ETS 300 019-2-7	Specification of environmental test: Portable and non-stationary use Test spec. T 7.3E: Partly weather protected and non-weather protected locations

2403 260 00087

7. Change History

Status	Version	Date	ECR	Comment / Changes	Initials of owner
Release	A	03.04.12	3654	First Release	CS/ET/EK/CP/RB

8. Disclaimer

Stresses above the Absolute Maximum Ratings may cause permanent damage to the device. These are stress ratings only. The device may not function when operated at these or any other conditions beyond those indicated under “Electrical and Acoustical Specifications”. Exposure beyond those indicated under “Electrical and Acoustical Specifications” for extended periods may affect device reliability.

This product is not qualified for use in automotive applications

Frequency range for Telekom use

The information contained in this literature is based on our experience to date and is believed to be reliable and it is subject to change without notice. It is intended as a guide for use by persons having technical skill at their own discretion and risk. We do not guarantee favorable results or assume any liability in connection with its use. Dimensions contained herein are for reference purposes only. For specific dimensional requirements consult factory. This publication is not to be taken as a license to operate under, or recommendation to infringe any exiting patents. This supersedes and voids all previous literature.